

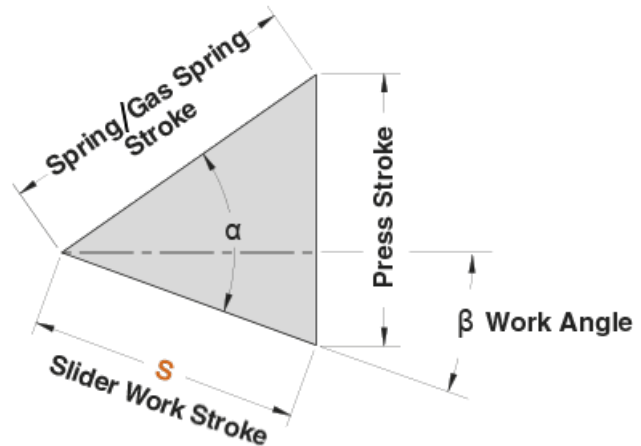

1. CAM DIAGRAM

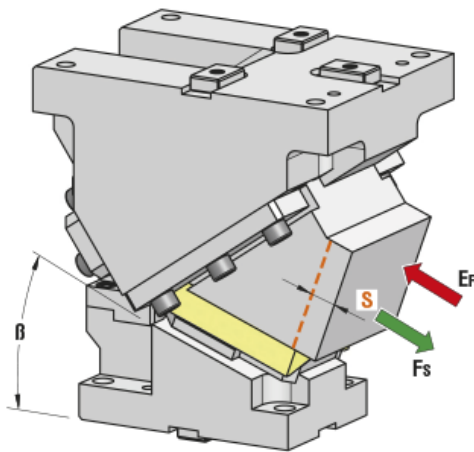

OMCR CODE	Work Angle β	Slider Work Stroke S (mm)	Press Stroke (mm)	Spring / Gas Spring Stroke (mm)	$\alpha - \beta$	α
CHD150.00	0°	28,68	40,96	50	55°	55°
CHD150.05	5°	32,26	41,11	50	50°	55°
CHD150.10	10°	35,90	41,59	50	45°	55°
CHD150.15	15°	39,65	42,40	50	40°	55°
CHD150.20	20°	43,59	43,59	50	35°	55°
CHD150.25	25°	47,78	45,19	50	30°	55°
CHD150.30	30°	52,33	47,29	50	25°	55°
CHD150.35	35°	57,36	50,00	50	20°	55°
CHD150.40	40°	63,05	53,47	50	15°	55°
CHD150.45	45°	69,64	57,92	50	10°	55°
CHD150.50	50°	77,49	63,72	50	5°	55°
CHD150.55	55°	87,17	71,41	50	0°	55°
CHD150.60	60°	99,62	81,92	50	-5°	55°
CHD150.65	65°	116,51	96,91	50	-10°	55°



2. WORK FORCE DISTRIBUTION (kN) FOR 1 MILLION CYCLES

The following diagrams illustrate the maximum possible ranges of camforce applicable in several portions of the work area but always working in the exact direction of slider work stroke. If several forces are applied simultaneously on the work area, their common center has to be specified and compared with the tabular infos. The sum of all forces has to be lower than the corresponding tabular value.



Max Work Force with shoulder



Max Work Force with fitting keys

Assembly with shoulder

$\beta=0^\circ \div 65^\circ$		WIDTH				
		30	30	30	30	30
HEIGHT	40	97	186	330	186	97
	40	116	221	391	221	116
	40	80	152	269	152	80

Assembly with fitting keys

$\beta=0^\circ \div 65^\circ$		WIDTH				
		30	30	30	30	30
HEIGHT	40	43	84	142	84	43
	40	52	99	150	99	52
	40	36	68	150	68	36